

CONSTRUCTION SERVICES AGREEMENT FOR**E.D. CROSKEY RECREATION CENTER RESTROOM REHABILITATION**

THIS CONSTRUCTION SERVICES AGREEMENT FOR ED CROSKEY CENTER RESTROOM REHABILITATION ("Agreement") is entered into by and between the **CITY OF OCALA**, a Florida municipal corporation ("City"), and **ADVANCED COMMERCIAL CONTRACTORS, INC.**, a for profit corporation duly organized and authorized to do business in the State of Florida (EIN: 59-3304942) ("Contractor").

RECITALS:

WHEREAS, on May 21, 2021, City issued an Invitation to Bid ("ITB") for the rehabilitation of restrooms at the E.D. Croskey Recreation Center, ITB No.: FAC/210434 (the "Solicitation"); and

WHEREAS, four (4) firms responded to the Solicitation and, after consideration of price and other evaluation factors set forth in the Solicitation, the bid submitted by Advanced Commercial Contractors, Inc. was found to be the lowest; and

WHEREAS, Advanced Commercial Contractors, Inc. was chosen as the intended awardee to provide construction services for the rehabilitation of restrooms at the E.D. Croskey Recreation Center (the "Project"); and

WHEREAS, Contractor certifies that Contractor and its subcontractors are qualified and possess the required licensure and skill to perform the work required for the Project; and

NOW THEREFORE, in consideration of the foregoing recitals, the following mutual covenants and conditions, and other good and valuable consideration, City and Contractor agree as follows:

TERMS OF AGREEMENT:

1. **RECITALS.** City and Contractor hereby represent, warrant, and agree that the Recitals set forth above are true and correct and are incorporated herein by reference.
2. **CONTRACT DOCUMENTS.** The Contract Documents which comprise the entire understanding between City and Contractor shall only include: (a) this Agreement; (b) those documents listed in this section as Exhibits to this Agreement; (c) the City's Solicitation for the Project and the bid submitted by Contractor in response to same (the "Solicitation Documents"); and (d) those documents identified in the Project Specifications section of this Agreement, if any. Each of these documents are incorporated herein by reference for all purposes.

If there is a conflict between the terms of this Agreement and the Contract Documents, then the terms of this Agreement shall control, amend, and supersede any conflicting terms contained in the remaining Contract Documents.

A. **Exhibits to Agreement:** The Exhibits to this Agreement are as follows:

Exhibit A: Scope of Work (A-1 through A-4)

Exhibit B: Hand Dryer Specifications (B-1 through B-2)

If there is a conflict between the individual Exhibits regarding the scope of work to be performed, then any identified inconsistency shall be resolved by giving precedence in the following order: (1) Exhibit A, then (2) Exhibit B.

B. **Project Specifications:** This project will require the Contractor to have the following specifications and documents, which are incorporated by reference:

i. **City of Ocala "Standard Specifications for Construction of Streets, Stormwater, Traffic, Water, and Sewer Infrastructure"** available at: <https://www.ocalafl.org/Home/ShowDocument?id=17908>.

ii. If there is a conflict between the Project Specifications regarding the scope of work to be performed, then any identified inconsistency shall be resolved by giving precedent to the most restrictive specification.

3. **SCOPE OF SERVICES.** Contractor shall provide all materials, labor, supervision, tools, accessories, equipment, permits, fees, testing, inspections, certifications, and all other things necessary for Contractor to perform its obligations under this Agreement as set forth in the attached **Exhibit A - Scope of Work** and the Solicitation Documents. The Scope of Work under this Agreement may only be adjusted by written amendment executed by both parties.

4. **COMPENSATION.** City shall pay Contractor a lump sum amount of **FIFTY-THREE THOUSAND AND NO/100 DOLLARS (\$53,000)** (the "Contract Sum") as full and complete compensation for the timely and satisfactory completion of the work in compliance with the Contract Documents. The pricing under this Agreement may only be adjusted by written amendment executed by both parties.

A. **Monthly Progress Payments:** The compensation amount under this section shall be paid by City, monthly, based upon a percentage of completion of the work as invoiced by Contractor and approved by City. The compensation sought under this Agreement is subject to the express terms of this Agreement and any applicable federal and/or state laws.

B. **Project Schedule and Progress Reports.** A progress report and updated project schedule must be submitted with each monthly pay request indicating the percent of services

completed to date. This report will serve as support for payment to Contractor and the basis for payment in the event project is suspended or abandoned.

- C. **Invoice Submission.** All invoices submitted by Contractor shall include the City Contract Number, an assigned Invoice Number, and an Invoice Date. Contractor shall be provided with a cover sheet for invoicing. This cover sheet must be filled out correctly and submitted with each invoice. Contractor shall submit the original invoice through the responsible City Project Manager at: **City of Ocala Facilities Management**, Attn: **Garrett Strong, 1805 NE 30th Avenue, Bldg. 1000, Ocala, Florida 34470**, E-Mail: gstrong@ocalafl.org.
 - D. **Payment of Invoices by City.** The City Project Manager must review and approve all invoices prior to payment. City Project Manager's approval shall not be unreasonably withheld, conditioned, or delayed. Payments by City shall be made no later than the time periods established in section 218.735, Florida Statutes.
 - E. **Withholding of Payment.** City reserves the right to withhold, in whole or in part, payment for any and all work that: (i) has not been completed by Contractor; (ii) is inadequate or defective and has not been remedied or resolved in a manner satisfactory to the City Project Manager; or (iii) which fails to comply with any term, condition, or other requirement under this Agreement. Any payment withheld shall be released and remitted to Contractor within **THIRTY (30)** calendar days of the Contractor's remedy or resolution of the inadequacy or defect.
 - F. **Excess Funds.** If due to mistake or any other reason Contractor receives payment under this Agreement in excess of what is provided for by the Agreement, Contractor shall promptly notify City upon discovery of the receipt of the overpayment. Any overpayment shall be refunded to City within **THIRTY (30)** days of Contractor's receipt of the overpayment or must also include interest calculated from the date of the overpayment at the interest rate for judgments at the highest rate as allowed by law.
 - G. **Tax Exemption.** City is exempt from all federal excise and state sales taxes (State of Florida Consumer's Certification of Exemption 85-8012621655C-9). The City's Employer Identification Number is 59-60000392. Contractor shall not be exempted from paying sales tax to its suppliers for materials to fulfill contractual obligations with the City, nor will Contractor be authorized to use City's Tax Exemption Number for securing materials listed herein.
5. **TIME FOR PERFORMANCE.** Time is of the essence with respect to the performance of all duties, obligations, and responsibilities set forth in this Agreement and the Contract Documents.

- A. Contractor shall mobilize and commence work no later than **FOURTEEN (14)** working days from the date of issuance of a Notice to Proceed for the project by City. At no time will the Contractor be allowed to lag behind.
 - B. **All work shall be substantially completed by Contractor in a manner satisfactory to the City Project Manager within FORTY-FIVE (45) days of the start date indicated on the Notice to Proceed and ready for final payment within FIVE (5) days of substantial completion.**
 - C. The Time for Performance under this Agreement may only be adjusted by Change Order, in the sole and absolute discretion of City. Any request for an extension of the Time for Performance must be submitted in a writing delivered to the City Project Manager, along with all supporting data, within **SEVEN (7)** calendar days of the occurrence of the event giving rise to the need for adjustment unless the City allows an additional period of time to ascertain more accurate data. All requests for adjustments in the Contract Time shall be determined by City.
 - D. As to any delay, inefficiency, or interference in this performance of this Agreement caused by any act or failure to act by City, the Contractor's sole remedy shall be the entitlement of an extension of time to complete the performance of the affected work in accordance with the Contract Documents. Contractor agrees to make no claim for extra or additional costs attributable to said delays, inefficiencies or interference, except as provided in this Agreement.
 - E. None of the provisions of this section shall exclude City's right of recovery for damages caused by delays or inefficiencies caused by any act or failure to act by Contractor, to include costs incurred by City for the procurement of additional professional services.
6. **FORCE MAJEURE.** Neither party shall be liable for delay, damage, or failure in the performance of any obligation under this Agreement if such delay, damage, or failure is due to causes beyond its reasonable control, including without limitation: fire, flood, strikes and labor disputes, acts of war, acts of nature, terrorism, civil unrest, pandemics, acts or delays in acting of the government of the United States or the several states, judicial orders, decrees or restrictions, or any other like reason which is beyond the control of the respective party ("Force Majeure"). The party affected by any event of force majeure shall use reasonable efforts to remedy, remove, or mitigate such event and the effects thereof with all reasonable dispatch.

The party affected by force majeure shall provide the other party with full particulars thereof including, but not limited to, the nature, details, and expected duration thereof, as soon as it becomes aware.

When force majeure circumstances arise, the parties shall negotiate in good faith any modifications of the terms of this Agreement that may be necessary or appropriate in order to arrive at an equitable solution. Contractor performance shall be extended for a number of days equal to the duration of the force majeure. Contractor shall be entitled to an extension of time only and, in no event, shall Contractor be entitled to any increased costs, additional compensation, or damages of any type resulting from such force majeure delays.

7. **INSPECTION AND ACCEPTANCE OF THE WORK.** Contractor shall report its progress to the City Project Manager as set forth herein. All services, work, and materials provided by Contractor under this Agreement shall be provided to the satisfaction and approval of the Project Manager.
 - A. The Project Manager shall decide all questions regarding the quality, acceptability, and/or fitness of materials furnished, or workmanship performed, the rate of progress of the work, the interpretation of the plans and specifications, and the acceptable fulfillment of the Agreement, in his or her sole discretion, based upon both the requirements set forth by City and the information provided by Contractor in its Proposal. The authority vested in the Project Manager pursuant to this paragraph shall be confined to the direction or specification of what is to be performed under this Agreement and shall not extend to the actual execution of the work.
 - B. Neither the Project Manager's review of Contractor's work nor recommendations made by Project Manager pursuant to this Agreement will impose on Project Manager any responsibility to supervise, direct, or control Contractor's work in progress or for the means, methods, techniques, sequences, or procedures of construction or safety precautions or programs incident Contractor's furnishing and performing the work.
8. **TERMINATION AND DEFAULT.** Either party, upon determination that the other party has failed or refused to perform or is otherwise in breach of any obligation or provision under this Agreement or the Contract Document, may give written notice of default to the defaulting party in the manner specified for the giving of notices herein. Termination of this Agreement by either party for any reason shall have no effect upon the rights or duties accruing to the parties prior to termination.
 - A. **Termination by City for Cause.** City shall have the right to terminate this Agreement immediately, in whole or in part, upon the failure of Contractor to carry out any obligation, term, or condition of this Agreement. City's election to terminate the Agreement for default shall be communicated by providing Contractor written notice of termination in the manner specified for the giving of notices herein. Any notice of termination given to

Contractor by City shall be effective immediately, unless otherwise provided therein, upon the occurrence of any one or more of the following events:

- (1) Contractor fails to timely and properly perform any of the services set forth in the specifications of the Agreement;
- (2) Contractor provides material that does not meet the specifications of the Agreement;
- (3) Contractor fails to complete the work required within the time stipulated in the Agreement; or
- (4) Contractor fails to make progress in the performance of the Agreement and/or gives City reason to believe that Contractor cannot or will not perform to the requirements of the Agreement.

B. **Contractor's Opportunity to Cure Default.** City may, in its sole discretion, provide Contractor with an opportunity to cure the violations set forth in City's notice of default to Contractor. Contractor shall commence to cure the violations immediately and shall diligently and continuously prosecute such cure to completion within a reasonable time as determined by City. If the violations are not corrected within the time determined to be reasonable by City or to the reasonable satisfaction of City, City may, without further notice, declare Contractor to be in breach of this Agreement and pursue all remedies available at law or equity, to include termination of this Agreement without further notice.

C. **City's Remedies Upon Contractor Default.** In the event that Contractor fails to cure any default under this Agreement within the time period specified in this section, City may pursue any remedies available at law or equity, including, without limitation, the following:

- (1) City shall be entitled to terminate this Agreement without further notice;
- (2) City shall be entitled to hire another contractor to complete the required work in accordance with the needs of City;
- (3) City shall be entitled to recover from Contractor all damages, costs, and attorney's fees arising from Contractor's default prior to termination; and
- (4) City shall be entitled to recovery from Contractor any actual excess costs by: (i) deduction from any unpaid balances owed to Contractor; or (ii) any other remedy as provided by law.

D. **Termination for Convenience.** City reserves the right to terminate this Agreement in whole or in part at any time for the convenience of City without penalty or recourse. The Project Manager shall provide written notice of the termination. Upon receipt of the notice, Contractor shall immediately discontinue all work as directed in the notice, notify all subcontractors of the effective date of the termination, and minimize all further costs to City including, but not limited to, the placing of any and all orders for materials,

facilities, or supplies, in connection with its performance under this Agreement. Contractor shall be entitled to receive compensation solely for: (1) the actual cost of the work completed in conformity with this Agreement; and/or (2) such other costs incurred by Contractor as permitted under this Agreement and approved by City.

9. **DELAYS AND DAMAGES.** The Contractor agrees to make no claim for extra or additional costs attributable to any delays, inefficiencies, or interference in the performance of this contract occasioned by any act or omission to act by the City except as provided in the Agreement. The Contractor also agrees that any such delay, inefficiency, or interference shall be compensated for solely by an extension of time to complete the performance of the work in accordance with the provision in the standard specification.
10. **PERFORMANCE EVALUATION.** At the end of the contract, City may evaluate Contractor's performance. Any such evaluation will become public record.
11. **WARRANTY.** Contractor warrants that all labor, materials, and equipment furnished under the agreement are new, of the type and quality required for the Project, and installed in a good and workmanlike manner in accordance with the Contract Documents. Contractor shall guarantee that the work shall be free from any defects in workmanship for a period of not less than **ONE (1) YEAR** from the date of Final Completion. Contractor shall guarantee that the materials provided shall be free from any defects for the longer of: (1) **ONE (1) YEAR** from the date of Final Completion; or (2) the period of warranty provided by any supplier or manufacturer. All written manufacturers' warranties for materials supplied must be provided to the City Project Manager before final payment will be authorized.
12. **NOTICE REGARDING FAILURE TO FULFILL AGREEMENT.** Any contractor who enters into an Agreement with the City of Ocala and fails to complete the contract term, for any reason, shall be subject to future bidding suspension for a period of **ONE (1)** year and bid debarment for a period of up to **THREE (3)** years for serious contract failures.
13. **CONTRACTOR REPRESENTATIONS.** Contractor expressly represents that:
 - A. Contractor has read and is fully familiar with all the terms and conditions of this Agreement, the Contract Documents, and other related data and acknowledges that they are sufficient in scope and detail to indicate and convey understanding of all terms and conditions of the work to be performed by Contractor under this Agreement.
 - B. Contractor has disclosed, in writing, all known conflicts, errors, inconsistencies, discrepancies, or omissions discovered by Contractor in the Contract Documents, and that the City's written resolution of same is acceptable to Contractor.
 - C. Contractor has had an opportunity to visit, has visited, or has had an opportunity to examine and ask questions regarding the sites upon which the work is to be performed

and is satisfied with the site conditions that may affect cost, progress, and performance of the work, as observable or determinable by Contractor's own investigation.

- D. Contractor is satisfied with the site conditions that may affect cost, progress, and performance of the work, as observable or determinable by Contractor's own investigation.
- E. Contractor is familiar with all local, state, and Federal laws, regulations, and ordinances which may affect cost, progress, or its performance under this Agreement whatsoever.
- F. **Public Entity Crimes.** Neither Contractor, its parent corporations, subsidiaries, members, shareholders, partners, officers, directors or executives, nor any of its affiliates, contractors, suppliers, subcontractors, or consultants under this Agreement have been placed on the convicted vendor list following a conviction of a public entity crime. Contractor understands that a "public entity crime" as defined in section 287.133(1)(g), Florida Statutes, is "a violation of any state or federal law by a person with respect to and directly related to the transaction of business with any public entity or with an agency or political subdivision of any other state or with the United States..." Contractor further understands that any person or affiliate who has been placed on the convicted vendor list following a conviction for a public entity crime: (1) may not submit a bid, proposal, or reply on a contract: (a) to provide any goods or services to a public entity; (b) for the construction or repair of a public building or public work; or (c) for leases of real property to a public entity; (2) may not be awarded or perform work as a contractor, supplier, subcontractor, or consultant under a contract with any public entity; and (3) may not transact business with any public entity in excess of the threshold amount provided in section 287.017, Florida Statutes, for CATEGORY TWO for a period of 36 months from the date of being placed on the convicted vendor list.

14. **CONTRACTOR RESPONSIBILITIES.** Except as otherwise specifically provided for in this Agreement, the following provisions are the responsibility of the Contractor:

- A. Contractor shall competently and efficiently supervise, inspect, and direct all work to be performed under this Agreement, devoting such attention thereto and applying such skills and expertise as may be necessary to perform the work in accordance with the Contract Documents.
- B. Contractor shall be solely responsible for the means, methods, techniques, sequences, or procedures of construction and safety precautions or programs incident thereto.
- C. Contractor shall be responsible to see that the finished work complies accurately with the contract and the intent thereof.

- D. Contractor shall comply with all local, state, and Federal laws, regulations, and ordinances which may affect cost, progress, or its performance under this Agreement, including, but not limited to obtaining all permits, licenses, and other authorizations necessary for the prosecution of the work and be responsible for all costs associated with same.
 - E. Contractor shall operate and cause all construction equipment and materials supplied for or intended to be utilized in the Project to be operated and stored in only those areas prescribed by City. This includes the operations of workmen.
 - F. Contractor shall be fully responsible for receipt, inspection, acceptance, handling, and storage of all construction equipment and materials supplied for or intended to be utilized in the Project, whether furnished by Contractor or City. Contractor shall be responsible for providing adequate safeguards to prevent loss, theft, damage, or commingling with other materials or projects.
 - G. Contractor shall continue its performance under this Agreement during the pendency of any dispute or disagreement arising out of or relating to this Agreement, except as Contractor and City may otherwise agree in writing.
15. **NO EXCLUSIVITY.** It is expressly understood and agreed by the parties that this is not an exclusive agreement. Nothing in this Agreement shall be construed as creating any exclusive arrangement with Contractor or as prohibit City from either acquiring similar, equal, or like goods and/or services or from executing additional contracts with other entities or sources.
16. **RIGHT OF ACCESS AND OTHER WORK PERFORMED BY THIRD-PARTIES.** City may perform additional work related to the Project itself, or have additional work performed by utility service companies, or let other direct contracts therefore which shall contain General Conditions similar to these. Contractor shall afford the utility service companies and the other contractors who are parties to such direct contracts (or City, if City is performing the additional work with City's employees) reasonable opportunity for the introduction and storage of materials and equipment and the execution of work and shall properly connect and coordinate his work with theirs.
- A. If any part of Contractor's work depends for proper execution or results upon the work of any such other contractor or utility service company (or City), Contractor shall inspect and promptly report to City in writing any latent or apparent defects or deficiencies in such work that render it unsuitable for such proper execution and results. Contractor's failure to so report shall constitute an acceptance of the other work as fit and proper for integration with Contractor's work except for latent or non-apparent defects and deficiencies in the other work.

- B. Contractor shall do all cutting, fitting, and patching of work that may be required to make the parts come together properly and integrate with such other work. Contractor shall not endanger any work of others by cutting, excavating, or otherwise altering their work, and will only cut or alter their work with the written consent of City.
17. **STORAGE OF MATERIALS/EQUIPMENT.** Contractor shall be fully responsible for receipt, inspection, acceptance, handling, and storage of equipment and materials (whether furnished by Contractor or City) to be utilized in the performance of or incorporated into the work.
18. **RESPONSIBILITIES OF CITY.** City or its representative shall issue all communications to Contractor. City has the authority to request changes in the work in accordance with the terms of this Agreement and with the terms in **Exhibit A – Scope of Work.** City has the authority to stop work or to suspend any work.
19. **COMMERCIAL AUTO LIABILITY INSURANCE.** Contractor shall procure and maintain, for the life of this Agreement, commercial auto liability insurance covering all automobiles owned, non-owned, hired, and scheduled by Contractor with a combined limit of not less than One Million Dollars (\$1,000,000) for bodily injury and property damage for each accident. Contractor’s commercial automobile liability insurance policy must name, as additional insured, the City of Ocala, a political subdivision of the State of Florida, and its officials, employees, and volunteers.
20. **COMMERCIAL GENERAL LIABILITY INSURANCE.** Contractor shall procure and maintain, for the life of this Agreement, commercial general liability insurance with minimum coverage limits not less than:
- A. One Million Dollars (\$1,000,000) per occurrence and Two Million Dollars (\$2,000,000) aggregate limit for bodily injury, property damage, and personal injury, and advertising injury; and
 - B. One Million Dollars (\$1,000,000) per occurrence and Two Million Dollars (\$2,000,000) aggregate limit for contractual liability, products and completed operations, independent contractors, and property in the care, control or custody of the Contractor.
 - C. Contractor’s commercial general liability insurance policy shall include Endorsement CG 20 10 11 85, or equivalent, naming as an additional insured the City of Ocala, a political subdivision of the State of Florida, and its officials, employees, and volunteers. The coverage shall contain no special limitation on the scope of protection afforded to City, its officials, employees, or volunteers.
21. **WORKERS’ COMPENSATION AND EMPLOYER’S LIABILITY COVERAGE.** Contractor shall procure and maintain, for the life of this Agreement, Workers’ Compensation insurance and employer’s liability coverage in amounts required by Florida law. If Contractor claims an

exemption from workers' compensation coverage, Contractor must provide a copy of the Certificate of Exemption from the Florida Division of Workers' Compensation for all officers or members of an LLC claiming exemption who will be participating in the Work. Contractor is solely responsible for compliance with any Federal workers' compensation laws such as Jones Act and USL&H Act, including any benefits available to any workers performing work on this Project. In case any class of employees engaged in hazardous work under this Agreement is not protected under Worker's Compensation statutes, the contractor shall provide and cause each subcontractor to provide adequate insurance satisfactory to the City for the protection of its employees not otherwise protected.

22. **MISCELLANEOUS INSURANCE PROVISIONS.**

- A. Insurance Requirements. These insurance requirements shall not relieve or limit the liability of Contractor. City does not in any way represent that these types or amounts of insurance are sufficient or adequate to protect Contractor's interests or liabilities but are merely minimums. No insurance is provided by the City under this contract to cover Contractor. **No work shall be commenced under this contract until the required Certificate(s) of Insurance have been provided.** Work shall not continue after expiration (or cancellation) of the Certificates of Insurance and shall not resume until new Certificate(s) of Insurance have been provided. Insurance written on a "Claims Made" form is not acceptable without consultation with City of Ocala Risk Management.
- B. Deductibles. Contractor is responsible for paying any and all deductibles or self-insured retention. Any deductibles or self-insured retentions above \$100,000 must be declared to and approved by the City. Approval will not be unreasonably withheld.
- C. Certificates of Insurance. Contractor shall provide Certificates of Insurance, accompanied by copies of all endorsements required by this section, that are issued by an agency authorized to do business in the State of Florida and with an A.M. Best rating* of A-V or greater. Renewal certificates must be forwarded to the **City of Ocala Contracting Department, Third Floor, 110 SE Watula Avenue, Ocala, FL 34471, E-Mail: vendors@ocalafl.org** prior to the policy expiration.
- D. Failure to Maintain Coverage. In the event Contractor fails to disclose each applicable deductible/self-insured retention or obtain or maintain in full force and effect any insurance coverage required to be obtained by Contractor under this Agreement, Contractor shall be considered to be in default of this Agreement.
- E. Severability of Interests. Contractor shall arrange for its liability insurance to include General Liability, Business Automobile Liability, and Excess/Umbrella Insurance, or to be endorsed to include a severability of interests/cross liability provision so that the "City of

Ocala" (where named as an additional insured) will be treated as if a separate policy were in existence, but without increasing the policy limits.

- F. Mandatory Endorsements for All Required Policies. All required policies shall include: (i) endorsement that waives any right of subrogation against the City of Ocala for any policy of insurance provided under this Agreement or under any state or federal worker's compensation or employer's liability act; and (ii) endorsement to give the City of Ocala no less than **THIRTY (30)** days written notice (with the exception of non-payment of premium which requires a **TEN (10)** calendar day notice) in the event of cancellation or material change.

23. **SAFETY/ENVIRONMENTAL.** Contractor shall be responsible for initiating, maintaining, and supervising all safety precautions and programs in connection with the Work. Contractor shall make an effort to detect hazardous conditions and shall take prompt action where necessary to avoid accident, injury or property damage. EPA, DEP, OSHA and all other applicable safety laws and ordinances shall be followed as well as American National Standards Institute Safety Standards. Contractor shall take all necessary precautions for the safety of, and shall provide the necessary protection to prevent damage, injury, or loss to:

- A. All employees on the work and other persons that may be affected thereby;
- B. All work, materials and equipment to be incorporated therein, whether in storage on or off the site; and
- C. Other property at the site or adjacent thereto, including trees, shrubs, lawns, walks, pavements, roadways, structures, and utilities not designated for removal, relocation, or replacement in the course of construction.

All, injury, or loss to any property caused, directly or indirectly, in whole or in part, by Contractor, any subcontractor, or anyone directly or indirectly employed by any of them, or anyone for whose acts any of them may be liable, shall be remedied by Contractor. Contractor's duties and responsibilities for the safety and protection of the work shall continue until such time as the work is completed and accepted by City.

24. **TRAFFIC CONTROL AND BARRICADES.** The Contractor shall mitigate impact on local traffic conditions to all extents possible. The Contractor is responsible for establishing and maintaining appropriate traffic control and barricades. The Contractor shall provide sufficient signing, flagging and barricading to ensure the safety of vehicular and pedestrian traffic at all locations where work is being done under this Agreement.

- A. In addition to the requirements set forth in bid, the Contractor shall maintain at all times a good and sufficient fence, railing or barrier around all exposed portions of said work in such a manner as to warn vehicular and pedestrian traffic of hazardous conditions.

- B. Should Contractor fail to properly barricade his work or stored material sites in the manner outlined above, the City may have the necessary barricading done, and all cost incurred for said barricading shall be charged to the Contractor.
25. **WORK SITE AND CLEANUP.** Daily, during the progress of the work, Contractor shall keep the premises free from accumulations of waste materials, rubbish, and all other debris resulting from the work. At the completion of the work, Contractor shall remove all waste materials, rubbish, and debris from and about the premises, as well as all tools, appliances, construction equipment and machinery, and surplus materials, and shall leave the site clean and ready for occupancy by City. Contractor shall provide an inventory listing of all surplus materials in an area designated by City. Contractor shall restore to their original condition those portions of the site not designated or alteration by the Contract.
26. **NON-DISCRIMINATORY EMPLOYMENT PRACTICES.** During the performance of the contract, the Contractor shall not discriminate against any employee or applicant for employment because of race, color, religion, ancestry, national origin, sex, pregnancy, age, disability, sexual orientation, gender identity, marital or domestic partner status, familial status, or veteran status and shall take affirmative action to ensure that an employee or applicant is afforded equal employment opportunities without discrimination. Such action shall be taken with reference to, but not limited to: recruitment, employment, termination, rates of pay or other forms of compensation and selection for training or retraining, including apprenticeship and on-the-job training.
27. **SUBCONTRACTORS.** Nothing in this Agreement shall be construed to create, impose, or give rise to any duty owed by City or its representatives to any subcontractor of Contractor or any other persons or organizations having a direct contract with Contractor, nor shall it create any obligation on the part of City or its representatives to pay or seek payment of any monies to any subcontractor of Contractor or any other persons or organizations having a direct contract with Contractor, except as may otherwise be required by law. City shall not be responsible for the acts or omissions of any Contractor, subcontractor, or of any of their agents or employees, nor shall it create any obligation on the part of City or its representatives to pay or to seek the payment of any monies to any subcontractor or other person or organization, except as may otherwise be required by law.
28. **EMERGENCIES.** In an emergency affecting the welfare and safety of life or property, Contractor, without special instruction or authorization from the City Project Manager, is hereby permitted, authorized and directed to act at its own discretion to prevent threatened loss or injury. Except in the case of an emergency requiring immediate remedial work, any work performed after regular working hours, on Saturdays, Sundays or legal holidays, shall

be performed without additional expense to the City unless such work has been specifically requested and approved by the City Project Manager. Contractor shall be required to provide to the City Project Manager with the names, addresses and telephone numbers of those representatives who can be contacted at any time in case of emergency. Contractor's emergency representatives must be fully authorized and equipped to correct unsafe or excessively inconvenient conditions on short notice by City or public inspectors.

29. **INDEPENDENT CONTRACTOR STATUS.** Contractor acknowledges and agrees that under this Agreement, Contractor and any agent or employee of Contractor shall be deemed at all times to be an independent contractor and shall be wholly responsible for the manner in which it performs the services and work required under this Agreement. Neither Contractor nor its agents or employees shall represent or hold themselves out to be employees of City at any time. Neither Contractor nor its agents or employees shall have employee status with City. Nothing in this Agreement shall constitute or be construed to create any intent on the part of either party to create an agency relationship, partnership, employer-employee relationship, joint venture relationship, or any other relationship which would allow City to exercise control or discretion over the manner or methods employed by Contractor in its performance of its obligations under this Agreement.
30. **ACCESS TO FACILITIES.** City shall provide Contractor with access to all City facilities as is reasonably necessary for Contractor to perform its obligations under this Agreement.
31. **ASSIGNMENT.** Neither party may assign its rights or obligations under this Agreement to any third party without the prior express approval of the other party, which shall not be unreasonably withheld.
32. **RIGHT OF CITY TO TAKE OVER CONTRACT.** Should the work to be performed by Contractor under this Agreement be abandoned, or should Contractor become insolvent, or if Contractor shall assign or sublet the work to be performed hereunder without the written consent of City, the City Project Manager shall have the power and right to hire and acquire additional men and equipment, supply additional material, and perform such work as deemed necessary for the completion of this Agreement. Under these circumstances, all expenses and costs actually incurred by City to accomplish such completion shall be credited to City along with amounts attributable to any other elements of damage and certified by the Project Manager. The City Project Manager's certification as to the amount of such liability shall be final and conclusive.
33. **PUBLIC RECORDS.** The Contractor shall comply with all applicable provisions of the Florida Public Records Act, Chapter 119, Florida Statutes. Specifically, the Contractor shall:
 - A. Keep and maintain public records required by the public agency to perform the service.

- B. Upon request from the public agency's custodian of public records, provide the public agency with a copy of the requested records or allow the records to be inspected or copied within a reasonable time at a cost that does not exceed the cost provided in Chapter 119, Florida Statutes, or as otherwise provided by law.
- C. Ensure that public records that are exempt or confidential and exempt from public records disclosure requirements are not disclosed except as authorized by law for the duration of the contract term and following completion of the contract if the Contractor does not transfer the records to the public agency.
- D. Upon completion of the contract, transfer, at no cost, to the public agency all public records in possession of the Contractor or keep and maintain public records required by the public agency to perform the service. If the Contractor transfers all public records to the public agency upon completion of the contract, the Contractor shall destroy any duplicate public records that are exempt or confidential and exempt from public records disclosure requirements. If the Contractor keeps and maintains public records upon completion of the contract, the Contractor shall meet all applicable requirements for retaining public records. All records stored electronically must be provided to the public agency, upon request from the public agency's custodian of public records, in a format that is compatible with the information technology systems of the public agency.

IF THE CONTRACTOR HAS QUESTIONS REGARDING THE APPLICATION OF CHAPTER 119, FLORIDA STATUTES, TO THE CONTRACTOR'S DUTY TO PROVIDE PUBLIC RECORDS RELATING TO THIS CONTRACT, CONTACT THE CUSTODIAN OF PUBLIC RECORDS AT: CITY OF OCALA, OFFICE OF THE CITY CLERK; 352-629-8266; E-mail: clerk@ocalafl.org; City Hall, 110 SE Watula Avenue, Ocala, FL 34471.

- 34. **AUDIT.** Contractor shall comply and cooperate immediately with any inspections, reviews, investigations, or audits relating to this Agreement as deemed necessary by the Florida Office of the Inspector General, the City's Internal or External auditors or by any other Florida official with proper authority.
- 35. **PUBLICITY.** Contractor shall not use City's name, logo, seal or other likeness in any press release, marketing materials, or other public announcement without City's prior written approval.

36. **E-VERIFY.** In accordance with Executive Order 11-116, Contractor shall utilize the U.S. Agency of Homeland Security's E-Verify system, <https://e-verify.uscis.gov/emp>, to verify the employment eligibility of all employees hired during the term of this Agreement. Contractor shall also require all subcontractors performing work under this Agreement to utilize the E-Verify system for any employees they may hire during the term of this Agreement.
37. **CONFLICT OF INTEREST.** Contractor is required to have disclosed, with the submission of their bid, the name of any officer, director, or agent who may be employed by the City. Contractor shall further disclose the name of any City employee who owns, directly or indirectly, any interest in Contractor's business or any affiliated business entity. Any additional conflicts of interest that may occur during the contract term must be disclosed to the City of Ocala Procurement Department.
38. **WAIVER.** The failure or delay of any party at any time to require performance by another party of any provision of this Agreement, even if known, shall not affect the right of such party to require performance of that provision or to exercise any right, power or remedy hereunder. Any waiver by any party of any breach of any provision of this Agreement should not be construed as a waiver of any continuing or succeeding breach of such provision, a waiver of the provision itself, or a waiver of any right, power or remedy under this Agreement. No notice to or demand on any party in any circumstance shall, of itself, entitle such party to any other or further notice or demand in similar or other circumstances.
39. **SEVERABILITY OF ILLEGAL PROVISIONS.** Wherever possible, each provision of this Agreement shall be interpreted in such a manner as to be effective and valid under the applicable law. Should any portion of this Agreement be declared invalid for any reason, such declaration shall have no effect upon the remaining portions of this Agreement.
40. **INDEMNITY.** Contractor shall indemnify City and its elected officials, employees and volunteers against, and hold City and its elected officials, employees and volunteers harmless from, all damages, claims, losses, costs, and expenses, including reasonable attorneys' fees, which City or its elected officials, employees or volunteers may sustain, or which may be asserted against City or its elected officials, employees or volunteers, arising out of the activities contemplated by this Agreement including, without limitation, harm or personal injury to third persons during the term of this Agreement to the extent attributable to the actions of Contractor, its agents, and employees.
41. **NO WAIVER OF SOVEREIGN IMMUNITY.** Nothing herein is intended to waive sovereign immunity by the City to which sovereign immunity may be applicable, or of any rights or limits of liability existing under Florida Statute § 768.28. This term shall survive the termination

of all performance or obligations under this Agreement and shall be fully binding until any proceeding brought under this Agreement is barred by any applicable statute of limitations.

42. **NOTICES.** All notices, certifications or communications required by this Agreement shall be given in writing and shall be deemed delivered when personally served, or when received if by facsimile transmission with a confirming copy mailed by registered or certified mail, postage prepaid, return receipt requested. Notices can be concurrently delivered by e-mail. All notices shall be addressed to the respective parties as follows:

If to Contractor:	Advanced Commercial Contractors, Inc. Attention: K. Wayne Holley 2502 E. Orange Avenue Eustis, Florida 32726 Phone: (352) 589-1200 Email: wayne@acc-fla.com
-------------------	---

If to City of Ocala:	Tiffany Kimball, Contracting Officer 110 SE Watula Avenue, 3rd Floor Ocala, Florida 34471 Phone: 352-629-8366 Fax: 352-690-2025 E-mail: tkimball@ocalafl.org
----------------------	---

Copy to:	Robert W. Batsel, Jr., Esquire Gilligan, Gooding, Batsel & Anderson, P.A. 1531 SE 36 th Avenue Ocala, Florida 34471 Phone: 352-867-7707 Fax: 352-867-0237 E-mail: rbatsel@ocalalaw.com
----------	---

43. **ATTORNEYS' FEES.** If any civil action, arbitration or other legal proceeding is brought for the enforcement of this Agreement, or because of an alleged dispute, breach, default or misrepresentation in connection with any provision of this Agreement, the successful or prevailing party shall be entitled to recover reasonable attorneys' fees, sales and use taxes, court costs and all expenses reasonably incurred even if not taxable as court costs (including,

without limitation, all such fees, taxes, costs and expenses incident to arbitration, appellate, bankruptcy and post-judgment proceedings), incurred in that civil action, arbitration or legal proceeding, in addition to any other relief to which such party or parties may be entitled. Attorneys' fees shall include, without limitation, paralegal fees, investigative fees, administrative costs, sales and use taxes and all other charges reasonably billed by the attorney to the prevailing party.

44. JURY WAIVER. IN ANY CIVIL ACTION, COUNTERCLAIM, OR PROCEEDING, WHETHER AT LAW OR IN EQUITY, WHICH ARISES OUT OF, CONCERNS, OR RELATES TO THIS AGREEMENT, ANY AND ALL TRANSACTIONS CONTEMPLATED HEREUNDER, THE PERFORMANCE HEREOF, OR THE RELATIONSHIP CREATED HEREBY, WHETHER SOUNDING IN CONTRACT, TORT, STRICT LIABILITY, OR OTHERWISE, TRIAL SHALL BE TO A COURT OF COMPETENT JURISDICTION AND NOT TO A JURY. EACH PARTY HEREBY IRREVOCABLY WAIVES ANY RIGHT IT MAY HAVE TO A TRIAL BY JURY. NEITHER PARTY HAS MADE OR RELIED UPON ANY ORAL REPRESENTATIONS TO OR BY ANY OTHER PARTY REGARDING THE ENFORCEABILITY OF THIS PROVISION. EACH PARTY HAS READ AND UNDERSTANDS THE EFFECT OF THIS JURY WAIVER PROVISION.

45. GOVERNING LAW. This Agreement is and shall be deemed to be a contract entered and made pursuant to the laws of the State of Florida and shall in all respects be governed, construed, applied and enforced in accordance with the laws of the State of Florida.

46. JURISDICTION AND VENUE. The parties acknowledge that a majority of the negotiations, anticipated performance and execution of this Agreement occurred or shall occur in Marion County, Florida. Any civil action or legal proceeding arising out of or relating to this Agreement shall be brought only in the courts of record of the State of Florida in Marion County or the United States District Court, Middle District of Florida, Ocala Division. Each party consents to the exclusive jurisdiction of such court in any such civil action or legal proceeding and waives any objection to the laying of venue of any such civil action or legal proceeding in such court and/or the right to bring an action or proceeding in any other court. Service of any court paper may be effected on such party by mail, as provided in this Agreement, or in such other manner as may be provided under applicable laws, rules of procedures or local rules.

47. **REFERENCE TO PARTIES.** Each reference herein to the parties shall be deemed to include their successors, assigns, heirs, administrators, and legal representatives, all whom shall be bound by the provisions hereof.
48. **MUTUALITY OF NEGOTIATION.** Contractor and City acknowledge that this Agreement is a result of negotiations between Contractor and City, and the Agreement shall not be construed in favor of, or against, either party because of that party having been more involved in the drafting of the Agreement.
49. **SECTION HEADINGS.** The section headings herein are included for convenience only and shall not be deemed to be a part of this Agreement.
50. **RIGHTS OF THIRD PARTIES.** Nothing in this Agreement, whether express or implied, is intended to confer any rights or remedies under or because of this Agreement on any persons other than the parties hereto and their respective legal representatives, successors and permitted assigns. Nothing in this Agreement is intended to relieve or discharge the obligation or liability of any third persons to any party to this Agreement, nor shall any provision give any third persons any right of subrogation or action over or against any party to this Agreement.
51. **AMENDMENT.** No amendment to this Agreement shall be effective except those agreed to in writing and signed by both parties to this Agreement.
52. **COUNTERPARTS.** This Agreement may be executed in counterparts, each of which shall be an original and all of which shall constitute the same instrument.
53. **ELECTRONIC SIGNATURE(S).** Contractor, if and by offering an electronic signature in any form whatsoever, will accept and agree to be bound by said electronic signature to all terms and conditions of this Agreement. Further, a duplicate or copy of the Agreement that contains a duplicated or non-original signature will be treated the same as an original, signed copy of this original Agreement for all purposes.
54. **ENTIRE AGREEMENT.** This Agreement, including exhibits, (if any) constitutes the entire Agreement between the parties hereto with respect to the subject matter hereof. There are no other representations, warranties, promises, agreements or understandings, oral, written or implied, among the Parties, except to the extent reference is made thereto in this Agreement. No course of prior dealings between the parties and no usage of trade shall be relevant or admissible to supplement, explain, or vary any of the terms of this Agreement. No representations, understandings, or agreements have been made or relied upon in the making of this Agreement other than those specifically set forth herein.

55. **LEGAL AUTHORITY.** Each person signing this Agreement on behalf of either party individually warrants that he or she has full legal power to execute this Agreement on behalf of the party for whom he or she is signing, and to bind and obligate such party with respect to all provisions contained in this Agreement.

IN WITNESS WHEREOF, the parties have executed this Agreement on 09 / 15 / 2021.

ATTEST:

CITY OF OCALA

Angel B. Jacobs

Justin Grabelle

Angel B. Jacobs
City Clerk

Justin Grabelle
City Council President

Approved as to form and legality:

**ADVANCED COMMERCIAL CONTRACTORS,
INC.**

Robert W. Batsel, Jr.

By: *K Wayne Holley*

Robert W. Batsel, Jr.
City Attorney

K Wayne Holley

(Printed Name)

President

(Title)

BACKGROUND

1. Contractor shall remodel the restrooms at the E.D. Croskey Recreation Center located at 1510 NW 4th St, Ocala, FL 34475.
2. Contractor shall provide all labor, equipment and materials (unless otherwise noted) necessary to complete this project per this scope of work.
3. All work shall be coordinated with the City Project Manager, Garrett Strong, 352-351-6796, e-mail: gstrong@ocalafl.org.

PERMIT REQUIREMENTS

1. **Permits Required:** Contractor will be responsible for obtaining the following City of Ocala permits at no additional cost to the City:
 - Plumbing
2. **Permit Fee Schedule:** For information regarding permitting fees, please visit the following link: <https://www.ocalafl.org/home/showpublisheddocument/490/637545367420930000>
3. **Construction Permit Applications:** For construction permits and related documents, please visit the following link: <https://www.ocalafl.org/government/city-departments-a-h/growth-management/building/construction-permits>

CONTRACTOR RESPONSIBILITIES

1. This Scope of Work applies to all restrooms throughout the E.D. Croskey Recreation Center main building located at 1510 NW 4th St, Ocala, FL 34475.
2. All work shall comply with current applicable local, national, and international building codes, including compliance with the Americans with Disabilities Act (ADA). Any changes to the location of any fixture to comply with these standards must be approved by the City of Ocala.
 - A. The Florida Building Code is available at: <https://floridabuilding.org/c/default.aspx>
3. Installation methods for all materials shall comply with industry standards and manufacturer recommendations.
4. At least one male and one female restroom shall remain open for the duration of the construction.
5. Power for east restrooms shall come from the electrical room adjacent to the weightlifting room.
6. Power for the north restrooms shall come from the subpanel located in the classroom between the two restrooms.
7. Floor tile shall be 12" x 24" porcelain. Tile shall be furnished by the City. Contractor shall provide mortar and all other required materials for installation. Mortar joints shall be 1/8".
8. Tile pattern shall be a fifty percent (50%) offset. Contractor shall install wall tile approximately 40" off the ground. Metal trim shall be used on exposed edges. Tile shall be furnished by the City.

9. Partitions shall match as closely as possible to existing layout while conforming with ADA regulations. Existing partition material shall be re-used and additional material (if required) shall match existing.
10. New standard commercial toilets and urinals shall be furnished and installed by the contractor.
 - A. Flush valves shall have automatic sensors.
 - B. Materials shall be provided by the Contractor and approved by the City of Ocala.
11. Sinks shall be installed in solid surface countertops with undermount sinks. City shall provide the countertops to be installed by Contractor.
 - A. Faucets shall have automatic sensors.
 - B. Materials shall be provided by Contractor, and approved by the City of Ocala.
12. Grab bars shall be installed where required by ADA standards.
 - A. Materials shall be approved by the City of Ocala.
 - B. Mirrors shall remain in place, or be reinstalled if removed.
13. Hand dryers, as described in **Exhibit B – Hand Dryer Specifications**, shall be installed in same location as the existing paper towel holders.
14. Contractor shall furnish and install new thresholds.
15. Contractor shall furnish and install no-touch hand soap dispensers. The same model shall be used in all restrooms. Old soap dispensers shall be removed, and the new units installed in the same location.
16. Baby changing stations shall be re-used and re-installed in the same locations.
17. Walls shall be repaired and painted. Contractor shall provide all materials and labor for painting. Paint and primer shall be furnished by City.
18. Contractor shall complete all work in accordance with policies and procedures of the City of Ocala and all applicable State and Federal laws, policies, procedures, and guidelines.
19. Contractor shall obtain and pay for any and licenses, additional equipment, dumping and/or disposal fees, etc., required to fulfill this Agreement.

CITY OF OCALA RESPONSIBILITIES

The City of Ocala will furnish, the following to Contractor for the performance of services:

1. Access to City building to perform the work.
2. Tiles shall be furnished by the City of Ocala.
3. Paint and primer for walls shall be provided by the City.

WORK HOURS

1. The normal/standard working hours for this project are 7:00 a.m. to 5:00 p.m. Monday through Friday, excluding City-observed holidays.

2. Contractor shall provide a (forty-eight) 48 hour advance notice to the City Project Manager for work outside normal shift hours. The city may decline the request.

EXECUTION OF WORK

1. Contractor is responsible for any and all damages including but not limited to: buildings, curbing, pavement, landscaping or irrigation systems caused by Contractor's activity. Should any public or private property be damaged or destroyed, Contractor, at its expense, shall repair or make restoration as acceptable to the City of destroyed or damaged property no later than one (1) month from the date damage occurred.
2. The City reserves the right to purchase any materials for Contractor to use. Contractor shall not charge a mark-up fee for material furnished by the City.
3. Contractor shall be responsible for the provision of adequate and proper safety precautions for both the workers and all persons in or around the work area.

CONTRACTOR EMPLOYEES AND EQUIPMENT

1. An employee roster must be provided to the City Project Manager.
2. Contractor must utilize competent employees in performing the work. Employees performing the work must be properly licensed or qualified as required by the scope/project.
3. Contractor shall provide an assigned Project Manager, who will be the primary point of contact. Contractor must provide a valid telephone number, email and address at all times to the City Project Manager. The telephone must be answered during normal working hours or voicemail must be available to take a message.
4. At the request of the City, Contractor must replace any incompetent, unfaithful, abusive or disorderly person in his or her employment. City and Contractor must each be promptly notified by the other of any complaints received.
5. Contractor's employees shall wear shirts or have a badge which identifies the company, and all trucks belonging to the Contractor must display the company's name.
6. The employees of Contractor must wear suitable work clothes and personal protective equipment as defined by OSHA (hard hats, bucket harnesses, etc.) and meeting National Electrical Safety Code (NESC) requirements as indicated for all work conducted and be as clean and in as good appearance as the job conditions permit.
7. Contractor will operate as an independent contractor and not as an agent, representative, partner or employee of the City of Ocala, and shall control his operations at the work site, and be solely responsible for the acts or omissions of his employees.
8. No smoking is allowed on City property or projects.
9. Contractor must possess/obtain all required equipment to perform the work. A list of equipment shall be provided to the City upon request.
10. Contractor must perform a minimum of 30% of the work with its own forces.

SITE HOUSEKEEPING AND CLEANUP

1. **Waste/Debris:** Contractor shall keep the premises free at all times from accumulation of waste materials and rubbish caused by operations and employees. Contractor will provide approved containers for collection and disposal of waste materials, debris, and rubbish. Contractor shall dispose of debris in a legal manner. At least once weekly, Contractor shall dispose of such waste materials, debris, and rubbish off-site.
2. **Cleanup:** Periodic cleanup to avoid hazards or interference with operations at the site, and to leave the site in a reasonable neat condition. Work site will be cleaned after each day of work.
3. **Water Use:** The use of water to prevent the blowing of dust and debris during cutting operations is mandatory.
4. **Final Cleaning:** Upon completion of work, clean entire project site as applicable.
 - A. Leave the work and adjacent areas affected in a cleaned condition satisfactory to the City Project Manager.
 - B. Remove any foreign materials from exposed surfaces.

SUBMITTALS

1. Contractor shall submit copies of permits and approvals for construction as required by laws and regulations of governing agencies.
2. Contractor shall submit temporary construction parking area plans, storage yard, storage trailer location, staging area plan, and plan for disposal of waste materials.

SAFETY

1. Contractor shall be fully responsible for meeting all OSHA, local, state and national codes concerning safety provisions for their employees, sub-contractors, all building and site occupants, staff, public, etc.
2. Contractor shall be responsible for securing their equipment, materials, clothing and other property.
3. Prior to completion, storage and adequate protection of all material and equipment will be the Contractor's responsibility.
4. In no event shall the City be responsible for any damages to any of Contractor's lost, damaged, destroyed or stolen equipment, materials, property or clothing.



VERDEdri®

WORLD DRYER Hi-Speed Surface-Mounted ADA Compliant Hand Dryers

VERDEdri is a high-speed, surface-mounted ADA compliant hand dryer with flexible controls and hygienic features. Combining simple, low cost ADA compliant installation, outstanding energy efficiency and extended motor life, VERDEdri provides facilities with low operating cost, long reliable service life and an attractive return on investment.



Product Benefits

- 12 second dry time
- Surface-mounted ADA compliance simplifies installation and reduces installation costs
- Energy efficient - low operating cost
- Adjustable speed and sound controls
- Extended life motor with replaceable brushes maximizes service life and minimizes maintenance downtime
- HEPA filter eliminates 99.97% of particles 0.3µm or larger
- Antimicrobial technology protects the treated surfaces on the dryer by inhibiting the growth of bacteria, mold and fungus that can cause stains, odors or deterioration
- Universal voltage – accepts 110-277 VAC input
- IP24 rating – protection against harmful water ingress
- Optional adapter kit¹ for top-entry surface-mounted conduit
- Durable and vandal resistant

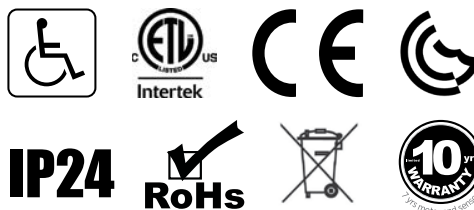

PERFORMANCE	
Dry Time:	12 seconds (adjustable)
Air Velocity:	150 – 225 mph (13,200 – 19,800 LFM)
Air Flow:	42 – 64 CFM
Air Temperature: (at 70° room temperature)	130°F
Sound at 79 in (2 m)	69 dBA

^{*}Sound measured at 79 in (2 m) in semi-anechoic chamber.

ELECTRICAL	
Voltage:	120 – 277 VAC (universal)
Power:	120 VAC 950 Watts 208 – 240 VAC 950 Watts 277 VAC 1150 Watts
Frequency:	50 / 60 Hz
Recommended Circuit:	Dedicated 15 Amp

¹The top entry adapter is used only where top entry surface mounted electrical connections are required. To meet ADA requirements when installed with the top entry adapter, do not install in walks, halls, corridors, passageways or aisles.

CONSTRUCTION	
Cover Options (Material / Finish)	Die Cast Aluminum (White) Die Cast Aluminum (Black) Stainless Steel (Brushed Finish) Stainless Steel (Polished Finish)
Motor	Thermally-protected universal type, through-flow discharge vacuum type, 5/8 HP, 31,000 RPM
Heating Element	Nichrome wire construction, 475 watts, with auto-reset thermal-protector so power is disconnected if air is not flowing
Electronic Controls	Universal voltage (120 – 277 V)
Filtration	HEPA Filter (standard – eliminates 99.97% particles 0.3 microns or larger (Accessory standard particulate filter available)
Speed Control	3 Speed Selector Switch
Activation	Automatic touch-free infrared activation with 45 second vandal-resistant lock out feature
Enclosure Security	Cover attached with tamper-resistant screws; security wrench included.
Electrical Connection Access	Access for wall mounted junction box and for bottom-entry surface mounted conduit (Accessory adapter ¹ available for top-entry surface mounted conduit)
10 Year Limited Warranty	Warranted by the manufacturer to be free from defects in material workmanship for a period of ten (10) years from the date of purchase. See warranty statement for limitations and exclusions.

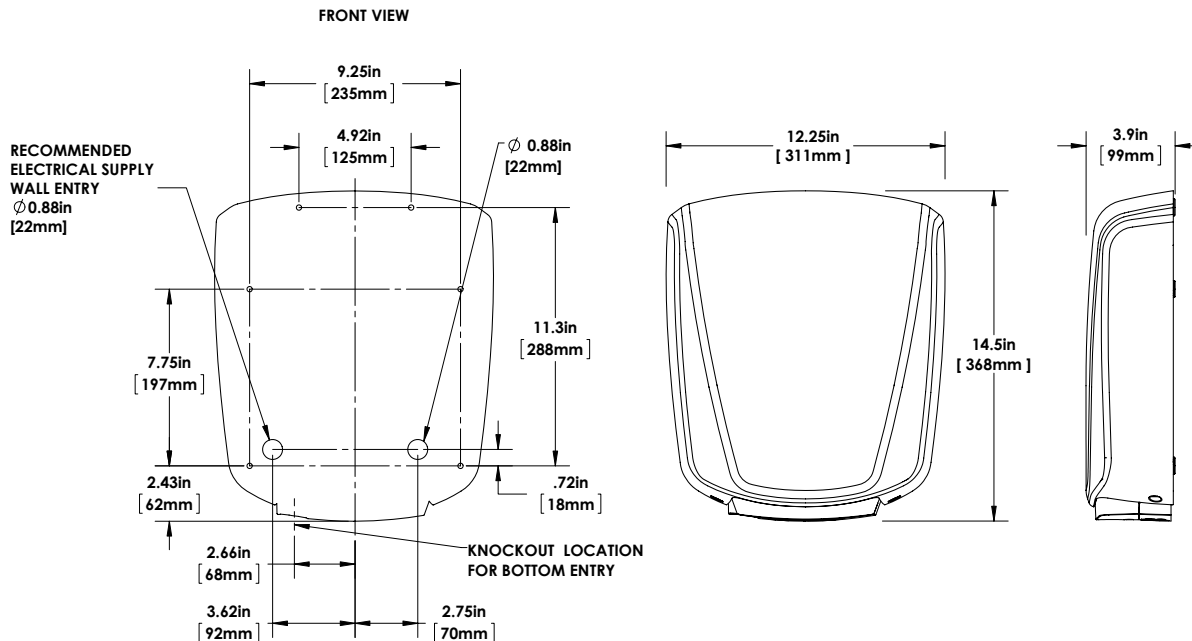

Placement Instruction

- Hand dryers should be spaced at least 2 feet apart, near but not over the washbasin
- In congested areas, dryers should be located to create a flow from wash basin to dryer to exit
- VERDEdri should be mounted at least 18" above or away from reflective surfaces, which may interfere with the automatic sensor operation.
- Dryer Quantity Recommendation:
 - Average Traffic: 1 dryer per 2 wash basins
 - Heavy Traffic: 1 dryer per wash basin
 - Industrial 54" Circular wash fountains: 4 dryers per sink

- Recommended mounting heights from floor to dryer bottom edge

Men's washrooms	46" (117 cm)
Women's washrooms	44" (112 cm)
Children's washrooms, ages 4-7	32" (81 cm)
Children's washrooms, ages 7-10	36" (91 cm)
Children's washrooms, ages 10-13	40" (102 cm)
Children's washrooms, ages 13-17	44" (112 cm)
Handicap Mounting Height	37" (94 cm)

Installation Guide

- VERDEdri hand dryers require a dedicated circuit and must be properly grounded
- One side of dryer should be mounted to a stud

Cover Material	Cover Finish / Kit	110-120 / 208 / 220-277 V	Unit Weight	Shipping Weight	Unit Size (HxWxD) inch/mm	Shipping Size (HxWxD) inch/mm
Aluminum	White	Q-974A2	8.3 lbs / 3.7 kgs	10.7 lbs / 4.8 kgs	14.5" x 12.25" x 3.9" 368 x 311 x 100	17.3" x 15.2" x 7.5" 440 x 385 x 190
Aluminum	Black	Q-162A2	8.3 lbs / 3.7 kgs	10.7 lbs / 4.8 kgs	14.5" x 12.25" x 3.9" 368 x 311 x 100	17.3" x 15.2" x 7.5" 440 x 385 x 190
Stainless Steel	Polished	Q-972A2	9.9 lbs / 4.4 kgs	12.2 lbs / 5.5 kgs	14.5" x 12.25" x 3.9" 368 x 311 x 100	17.3" x 15.2" x 7.5" 440 x 385 x 190
Stainless Steel	Brushed	Q-973A2	9.9 lbs / 4.4 kgs	12.2 lbs / 5.5 kgs	14.5" x 12.25" x 3.9" 368 x 311 x 100	17.3" x 15.2" x 7.5" 440 x 385 x 190
Optional Top Entry Adapter Kit		17-10504K	3.8 lbs / 1.7 kgs	6.2 lbs / 2.8 kgs	16" x 13.8" x 1.2" 406 x 350 x 30	16.9" x 14.8" x 3.5" 430 x 375 x 90
HEPA Filter		93-10490K	0.4 lbs / 0.9 kgs	0.7 lbs / 1.5 kgs	7.7" x 3.5" x 2.0" 195 x 90 x 50	9.5" x 3.5" x 3.5" 240 x 90 x 90
Accessory - Non-HEPA		93-10506K	0.4 lbs / 0.9 kgs	0.7 lbs / 1.5 kgs	7.7" x 2.0" x 2.0" 195 x 50 x 50	7.9" x 2.8" x 2.4" 200 x 70 x 60
Coarse Filter		93-10496	0.1 lbs / 0.05 kgs	0.5 lbs / 0.23 kgs	7.5" x 2.0" x 0.6" 190 x 52 x 16	10" x 5.0" x 1.0" 254 x 127 x 25

TITLE	For Signature: E.D. Croskey Center Restroom Rehabilitation...
FILE NAME	For Review - E D ...FAC 210434 v3.pdf
DOCUMENT ID	12253996955597a61aed4f8f9cb321a6e7581744
AUDIT TRAIL DATE FORMAT	MM / DD / YYYY
STATUS	● Completed

Document History



SENT

09 / 09 / 2021
07:56:33 UTC-4

Sent for signature to Advanced Commercial Contractors, Inc. (carla.advancedcommercialcont@gmail.com), Robert W. Batsel, Jr. (rbatsel@ocalalaw.com), Justin Grabelle (jgrabelle@ocalafl.org) and Angel B. Jacobs (ajacobs@ocalafl.org) from plewis@ocalafl.org
IP: 216.255.240.104



VIEWED

09 / 09 / 2021
09:33:26 UTC-4

Viewed by Advanced Commercial Contractors, Inc. (carla.advancedcommercialcont@gmail.com)
IP: 67.162.165.125



REASSIGNED

09 / 09 / 2021
10:58:42 UTC-4

The document has been reassigned by Advanced Commercial Contractors, Inc. (carla.advancedcommercialcont@gmail.com) to Kenneth Holley (wholley222@aol.com)
IP: 67.162.165.125



VIEWED

09 / 09 / 2021
11:00:38 UTC-4

Viewed by Kenneth Holley (wholley222@aol.com)
IP: 67.162.165.125

TITLE	For Signature: E.D. Croskey Center Restroom Rehabilitation...
FILE NAME	For Review - E D ...FAC 210434 v3.pdf
DOCUMENT ID	12253996955597a61aed4f8f9cb321a6e7581744
AUDIT TRAIL DATE FORMAT	MM / DD / YYYY
STATUS	● Completed

Document History



09 / 09 / 2021
11:01:55 UTC-4

Signed by Kenneth Holley (wholley222@aol.com)
IP: 67.162.165.125



09 / 14 / 2021
09:47:29 UTC-4

Viewed by Robert W. Batsel, Jr. (rbatsel@ocalalaw.com)
IP: 216.255.247.51



09 / 14 / 2021
11:48:47 UTC-4

Signed by Robert W. Batsel, Jr. (rbatsel@ocalalaw.com)
IP: 216.255.247.51



09 / 15 / 2021
17:28:43 UTC-4

Viewed by Justin Grabelle (jgrabelle@ocalafl.org)
IP: 24.250.246.81



09 / 15 / 2021
17:28:55 UTC-4

Signed by Justin Grabelle (jgrabelle@ocalafl.org)
IP: 24.250.246.81



09 / 16 / 2021
12:16:57 UTC-4

Viewed by Angel B. Jacobs (ajacobs@ocalafl.org)
IP: 216.255.240.104

TITLE	For Signature: E.D. Croskey Center Restroom Rehabilitation...
FILE NAME	For Review - E D ...FAC 210434 v3.pdf
DOCUMENT ID	12253996955597a61aed4f8f9cb321a6e7581744
AUDIT TRAIL DATE FORMAT	MM / DD / YYYY
STATUS	● Completed

Document History

**09 / 16 / 2021**
12:17:06 UTC-4Signed by Angel B. Jacobs (ajacobs@ocalafl.org)
IP: 216.255.240.104

COMPLETED

09 / 16 / 2021
12:17:06 UTC-4

The document has been completed.